

Portfolio – Tech 484

Automated Manufacturing Systems

Prof: Dr. Paul Liu

Fall 2002

California State University, Los Angeles

Frank Yan Liu

Course Description

- ◎ Applications and theories of advanced production system in automated manufacturing environments;
- ◎ Emphases include direct and computer numerical control, computer integrated manufacturing CAD/CAM; flexible manufacturing; group technology.

What is CAM?

Definition

- CAM is a abbreviation of Computer Assistance Manufacturing
- It is a effective utilization of computers in manufacturing.

Application

- Direct application: device monitoring and control, NC, PLC, manufacturing cell.
- Indirect applications (manufacturing support): planning, MRP(Material Requirements Planning), process planning, scheduling, inventory, shop floor control.

The history of manufacturing - Milestones

1. Skeleton: Hand tools – thousands of years to several thousands of years.
2. Muscle: Machine tools – industrial revolution, 18th century, custom made products.
3. Smartness: Gauges - late 19th century, interchangeability.
4. Resource management(mgmt): Mfg. System – early 20th century.
5. Nerve: NC, robot – 50, 60, 70's, FMS.
6. Brain: Intelligent mfg.

The history of CAM

1950's NC hardwired relay control, APT language for NC

1960's Industrial robot, interactive computer graphics

1970's CNC (computer numerical control), CAD/CAM, PLC device and cell control, 3D CAD

1980's Solid modeling, Factory networking, MAP/TOP, CIM (computer-intergraded manufacturing), Concurrent engineering

1990's Intelligent Mfg System

About Mastercam

Definition

- Mastercam is a powerful CAD/CAM application that let user design parts and choose from 2-through 5-axis milling, turning, wire EDM, lasers, model base development, surface, and solid modeling.

Content

- Basics of designing a 2D part and creating a contour toolpath
- Pocket toolpath
- Surface machining
- Using Operations Manager to edit, regenerate, and create the output code that is used by a CNC machine

2D Part

Elbow

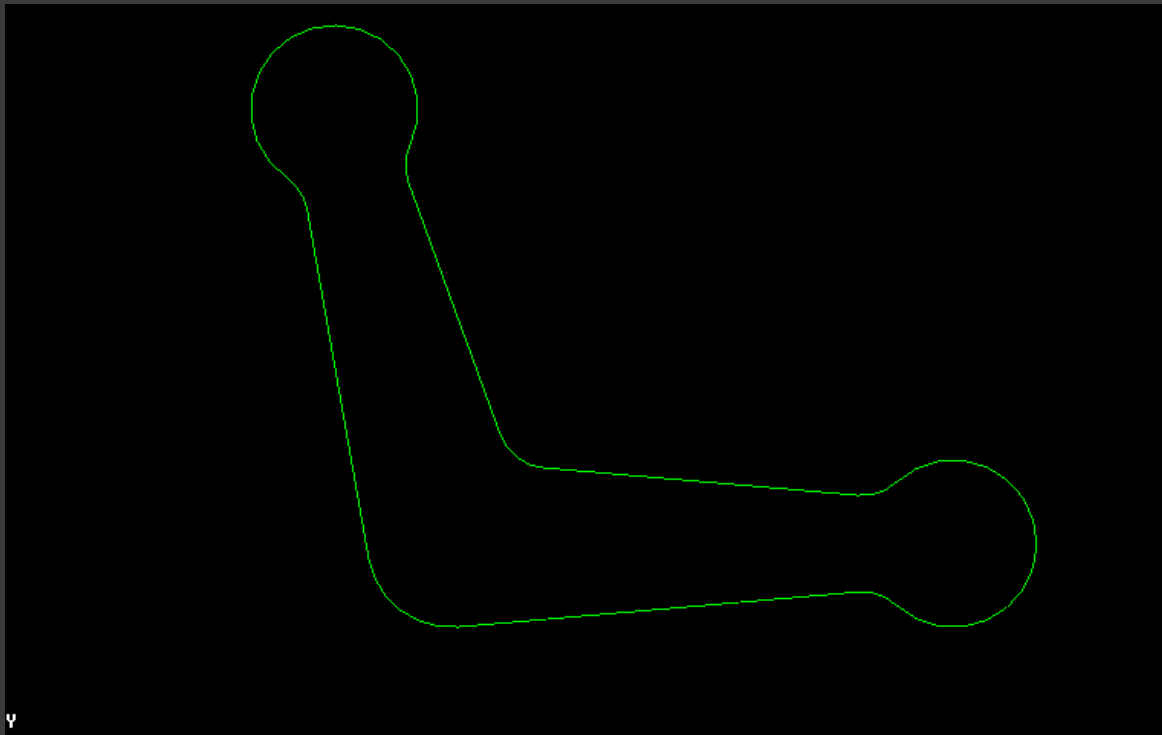

Mirroring the Elbow and Toolpath

Modifying a 2D Contour Tool path -Adding Roughing and Finishing Passes, creating a contour chamfer, mirroring the part and too path

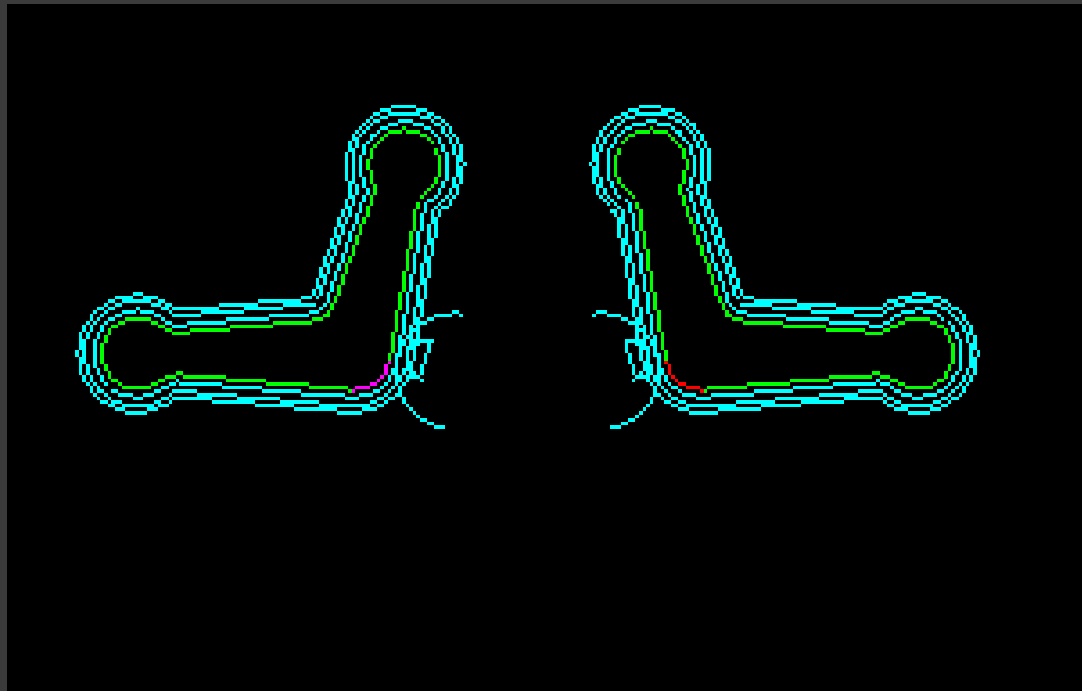

Rotating 2D Geometry and Contour Toolpath

Use arc, line, fillet, X form-Rotate, Modify-trim,
Divide tools.

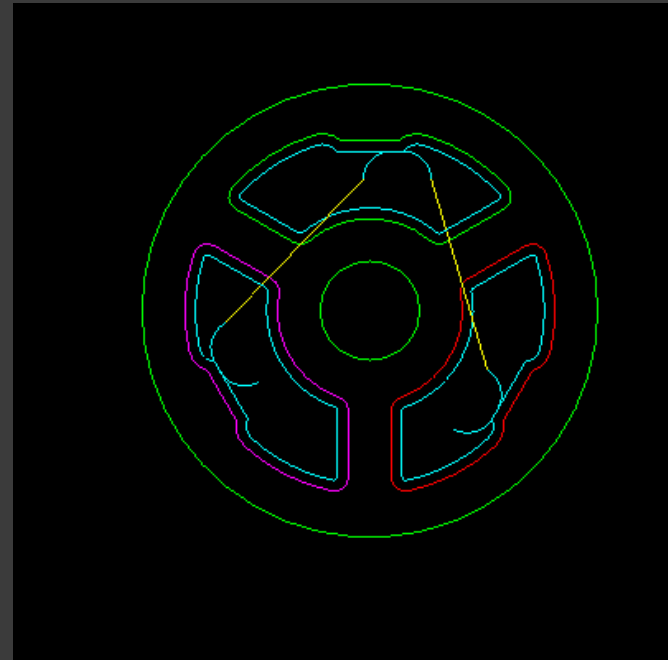
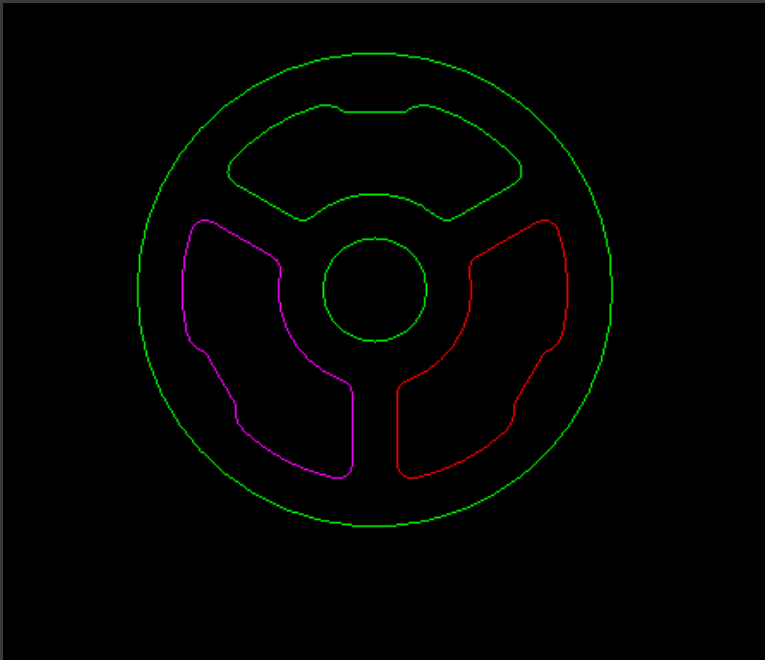

Contour Machining

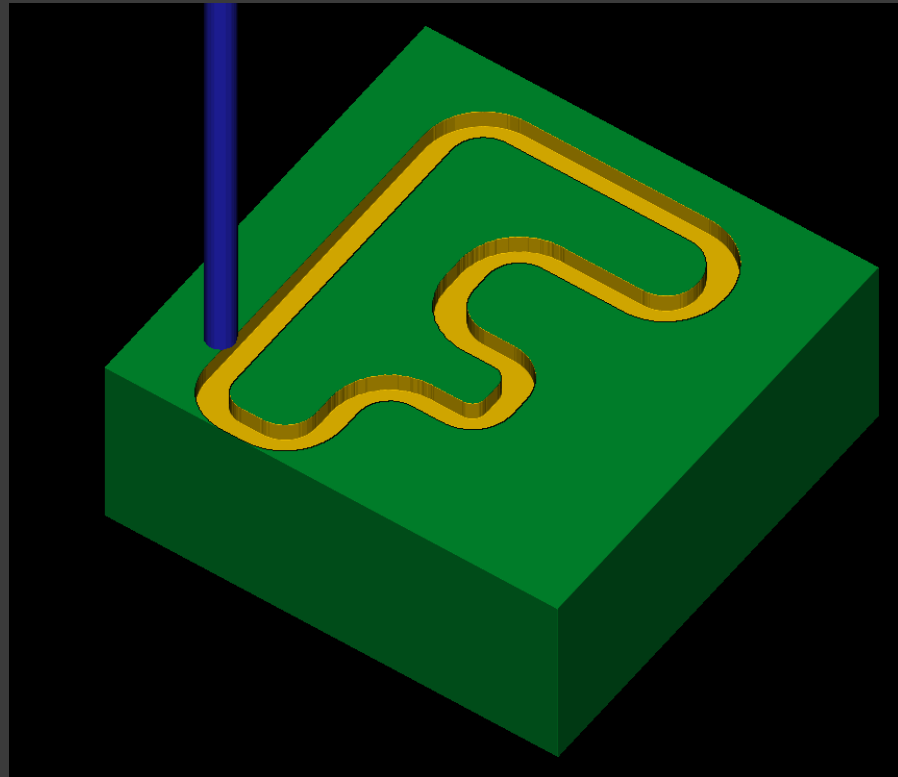

Creating new operations create new operations

Use Toolpath, Transform, Rotate tools and verify the toolpath.

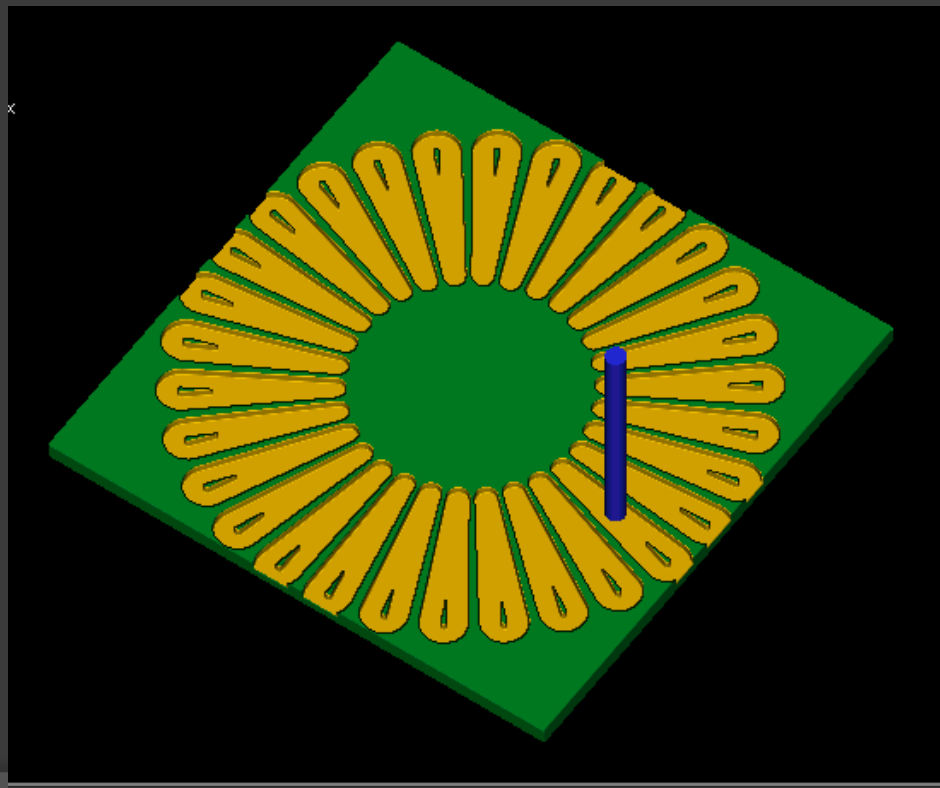

Project 1 - Pocket

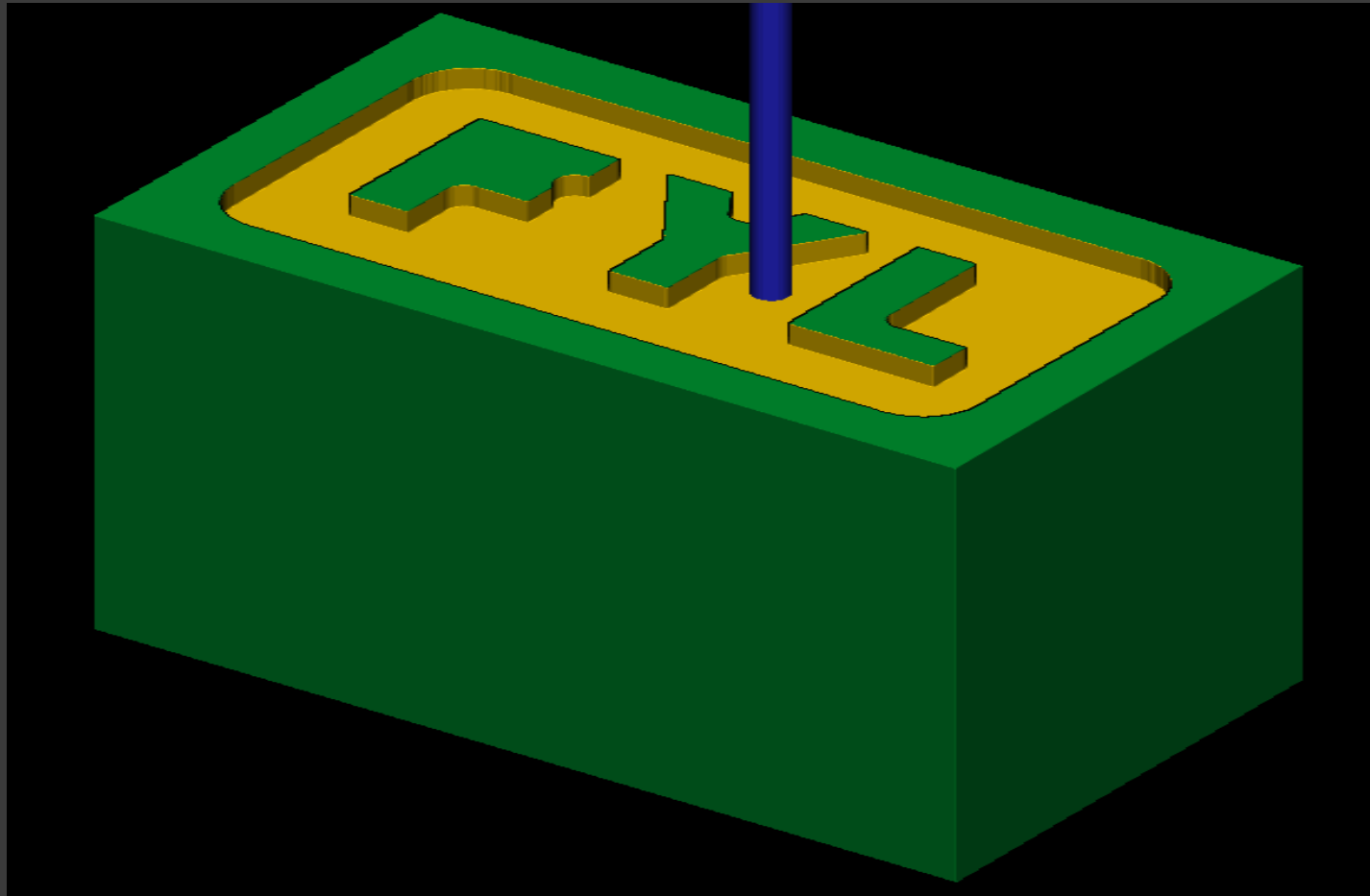

Remachining toolpath

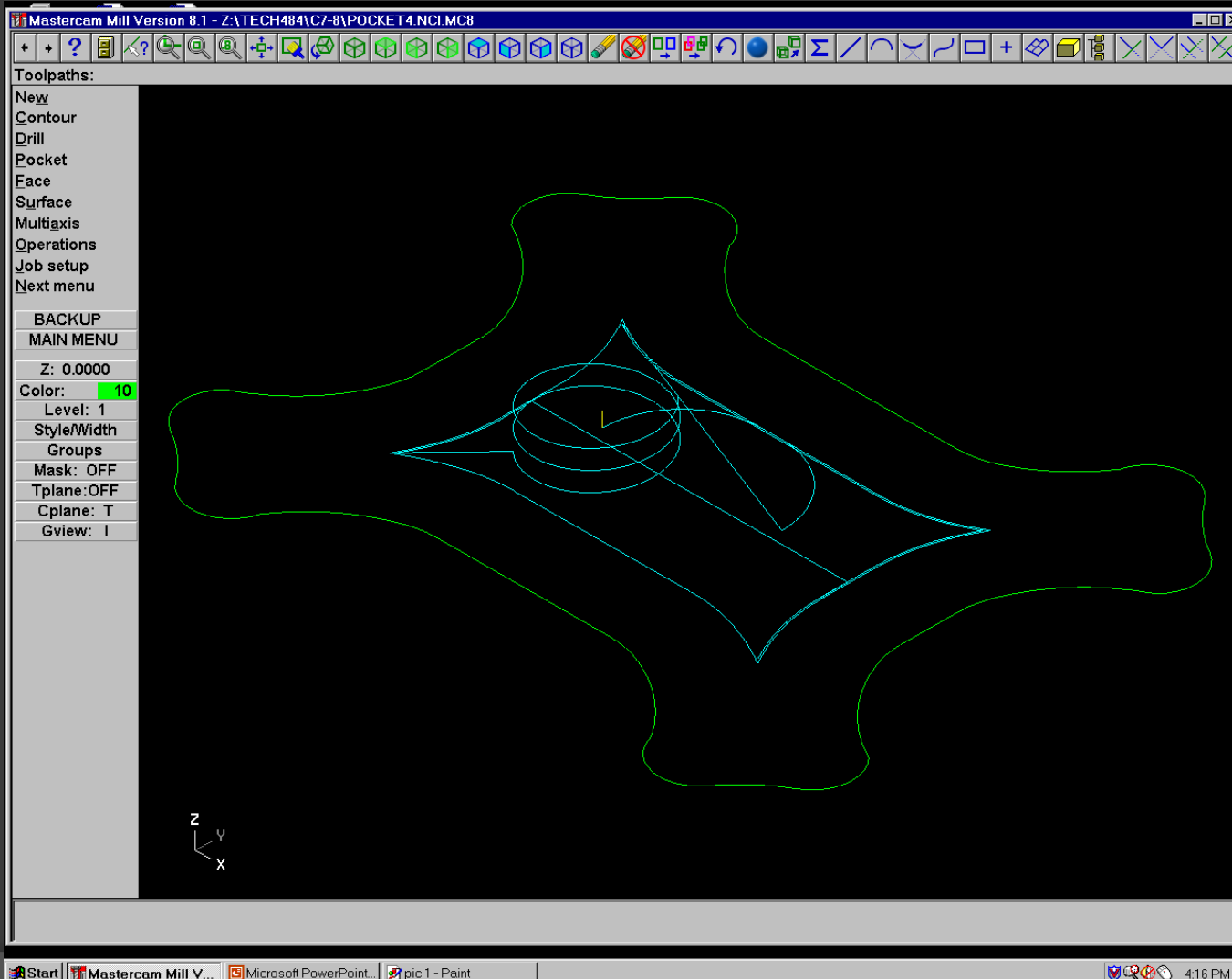

Remachining Surface

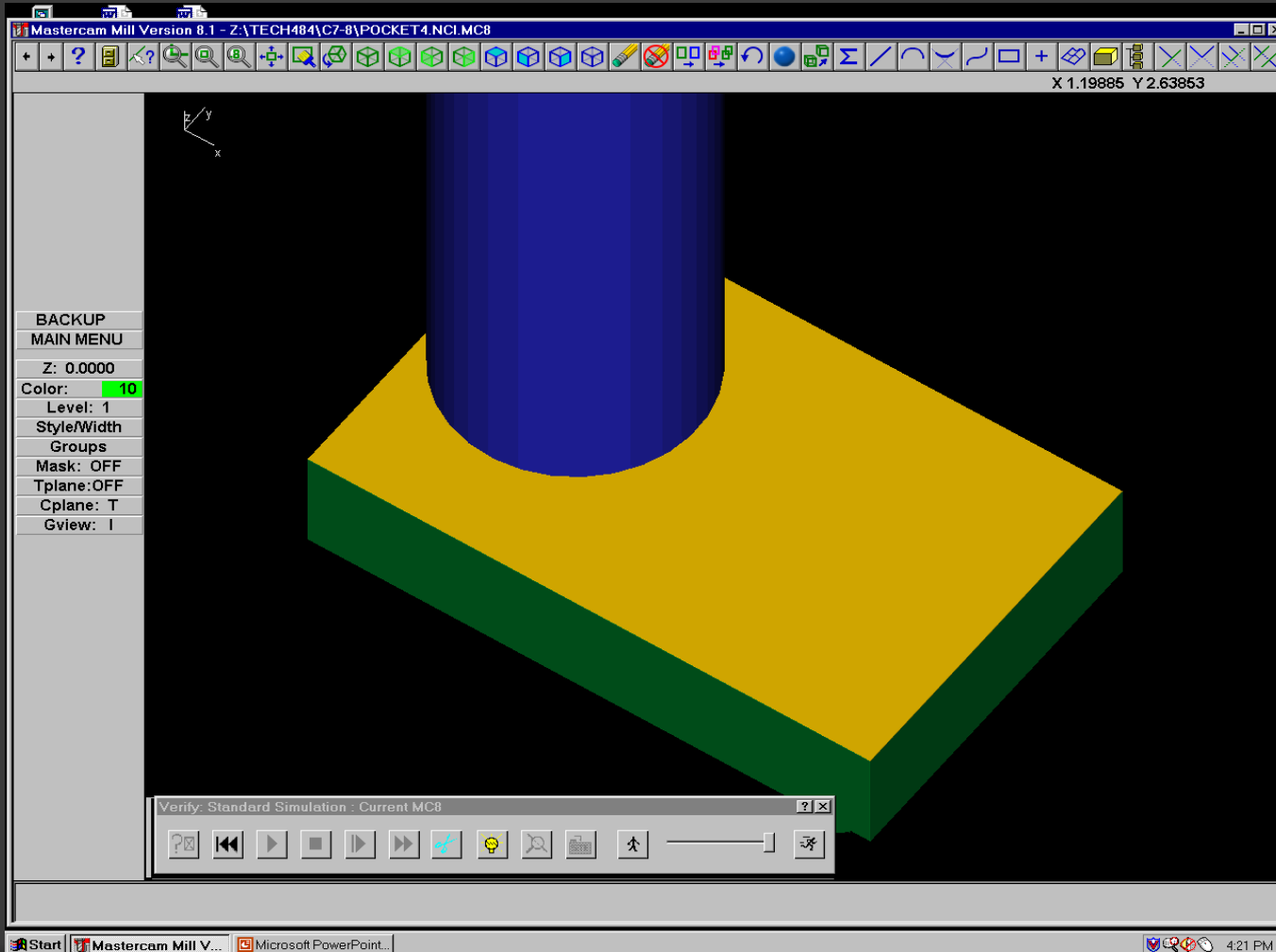

Surface

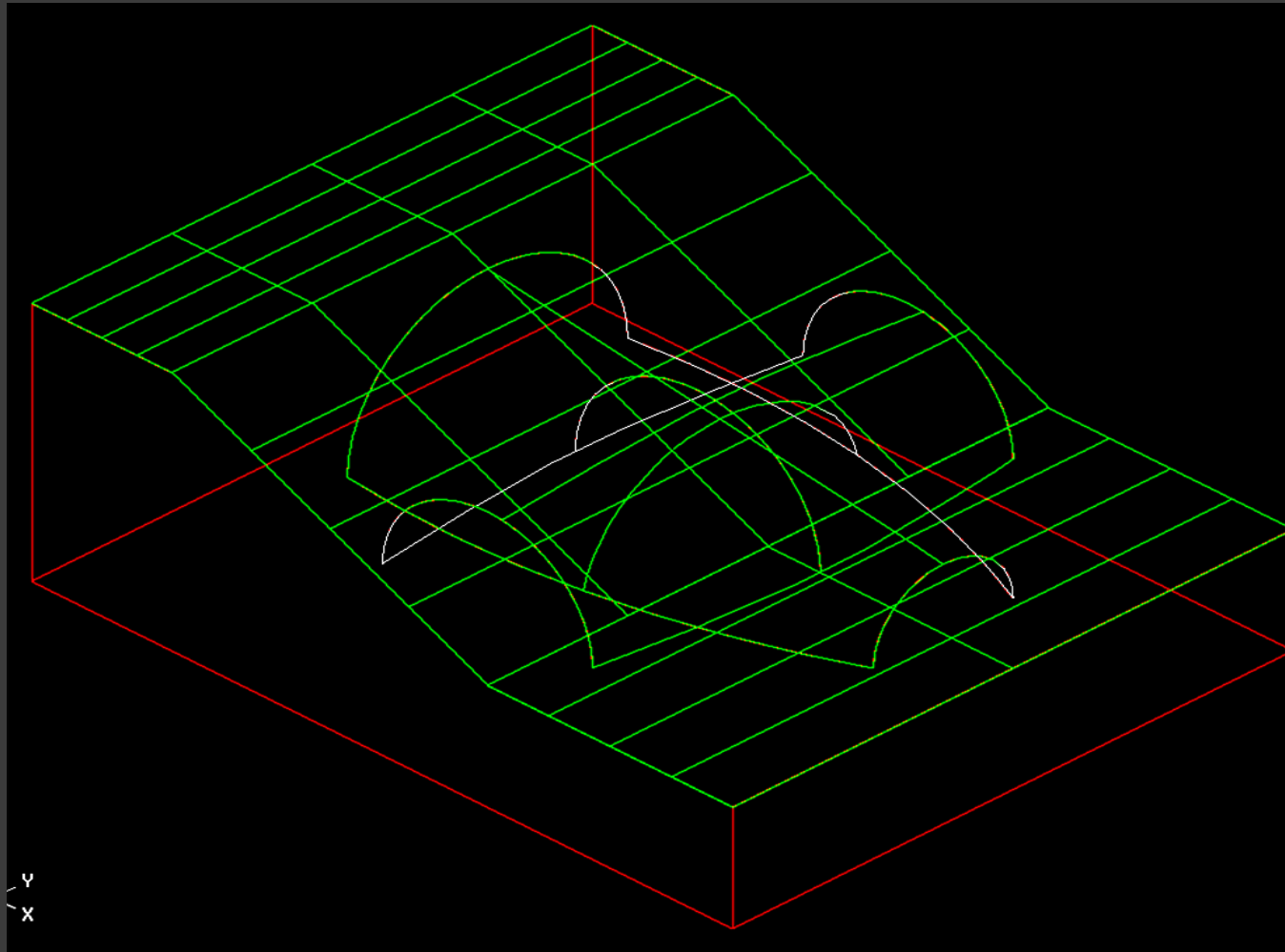

Rough Parallel Toolpath

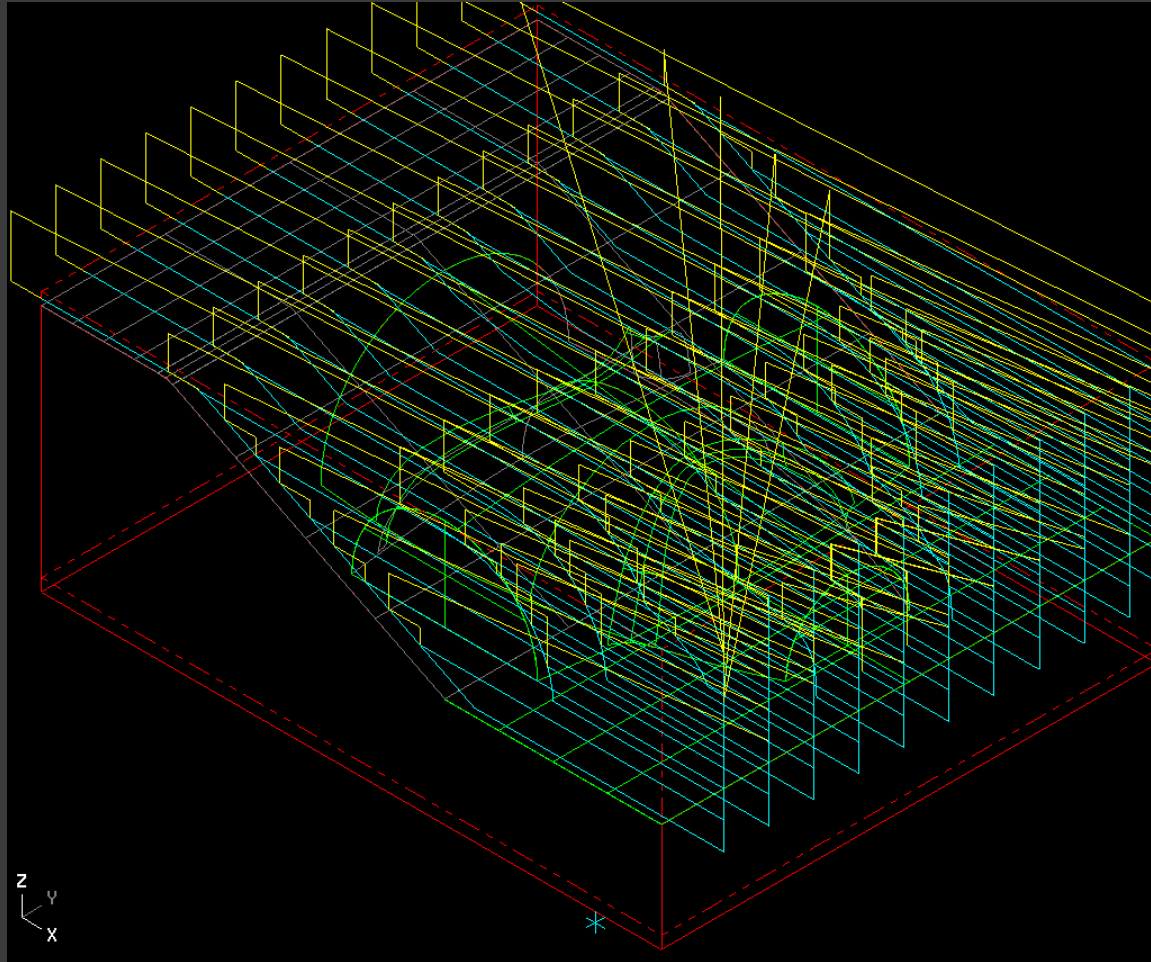

Fine Surface Toolpath

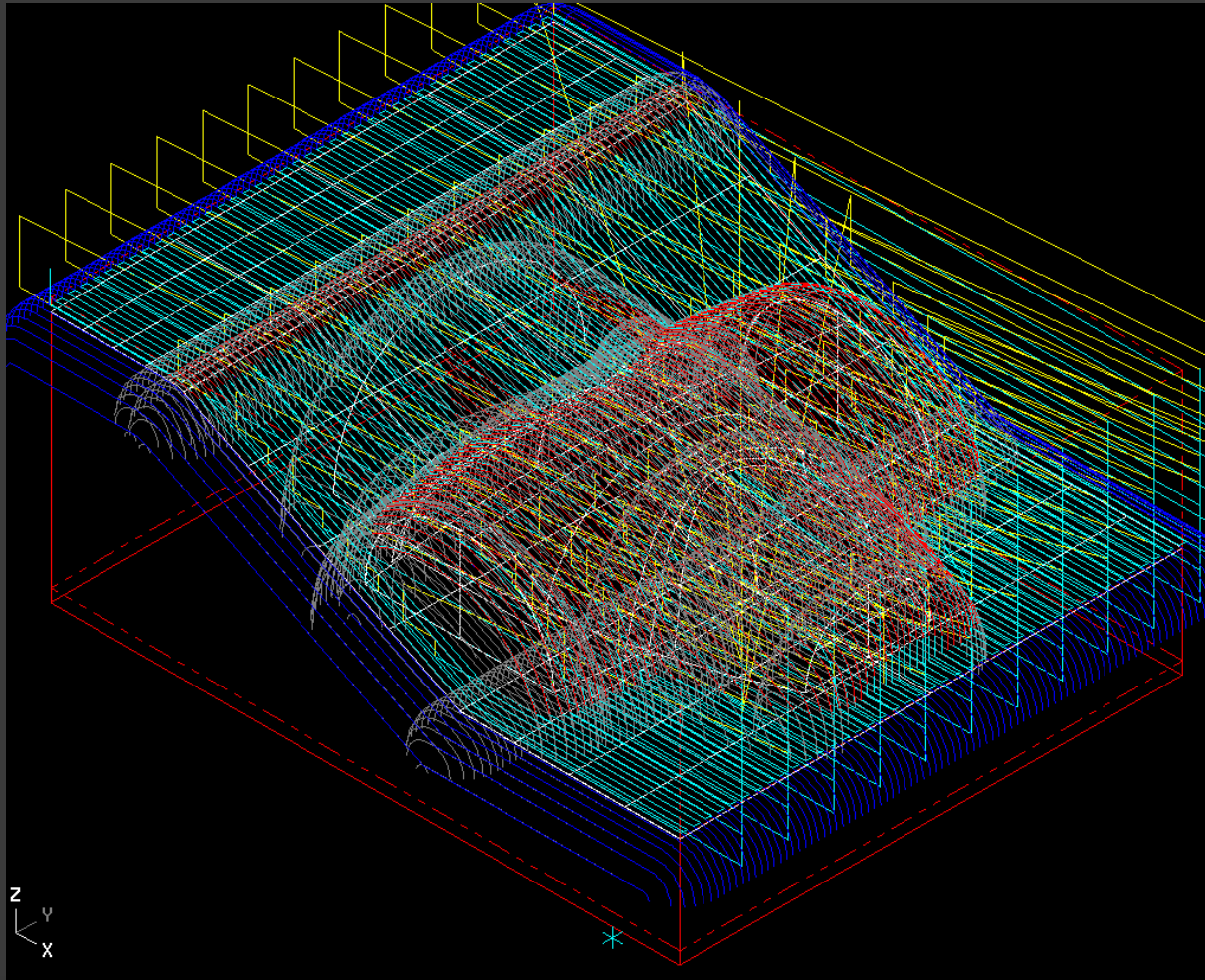

Fine Surface machined

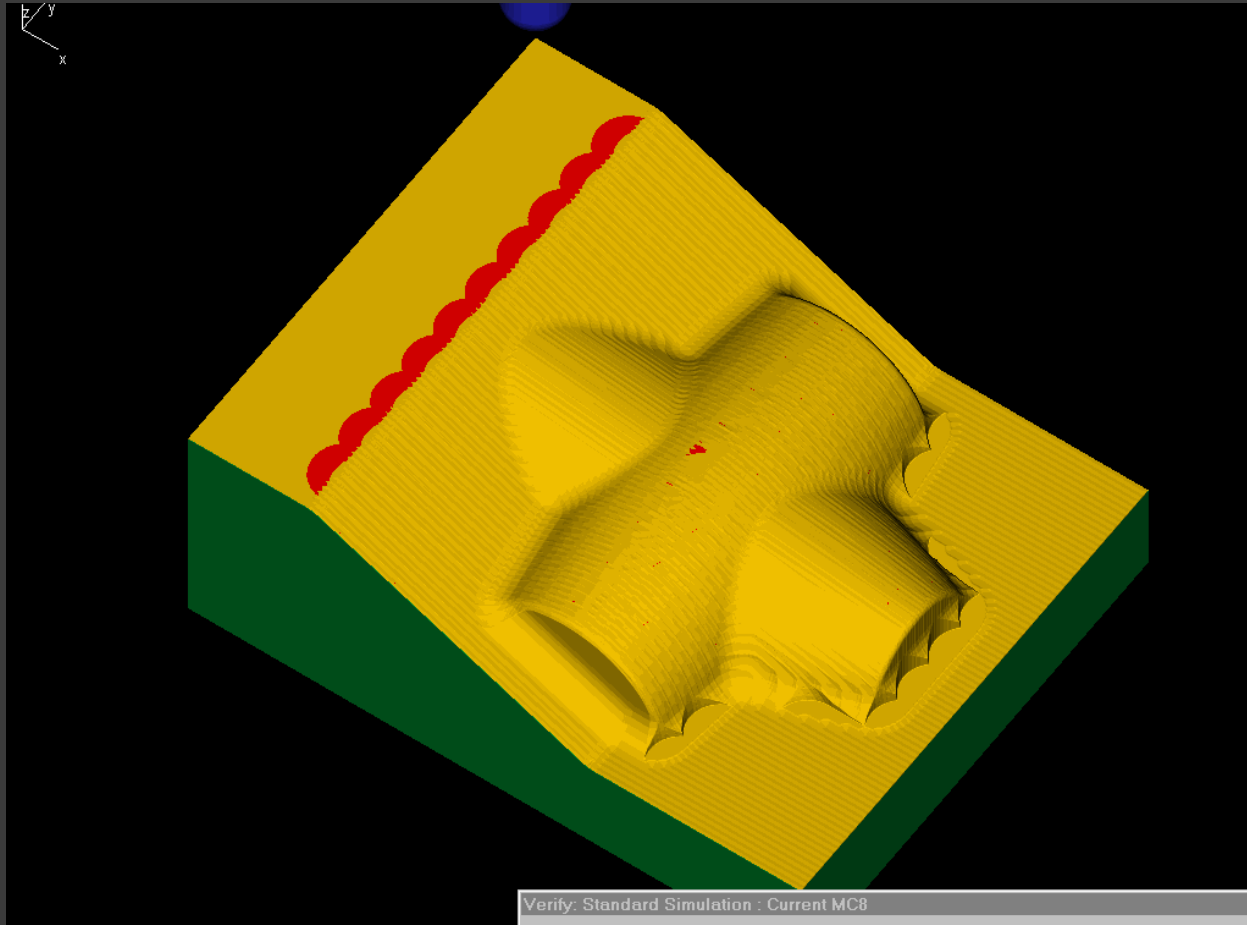

Revolved Surface - Parallel

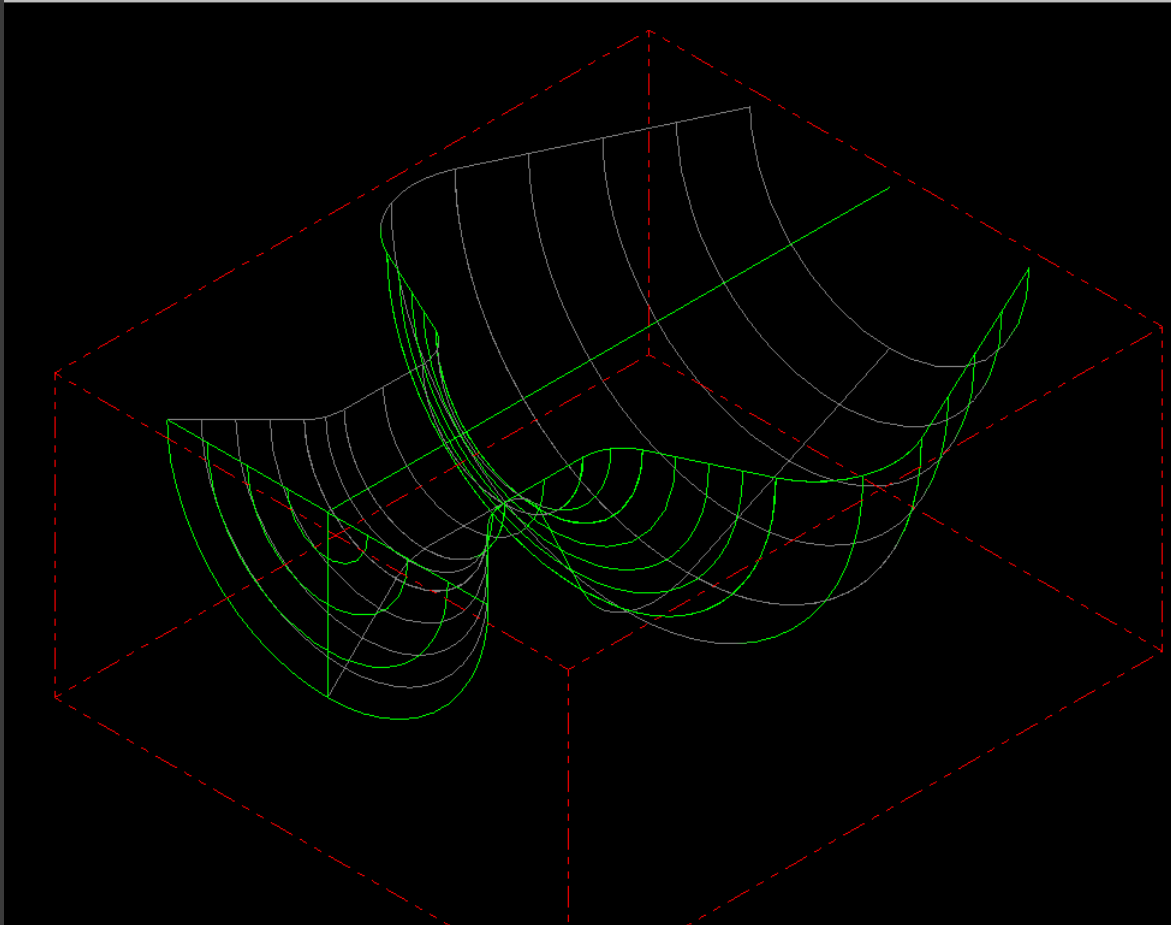

Revolved Surface – Finished

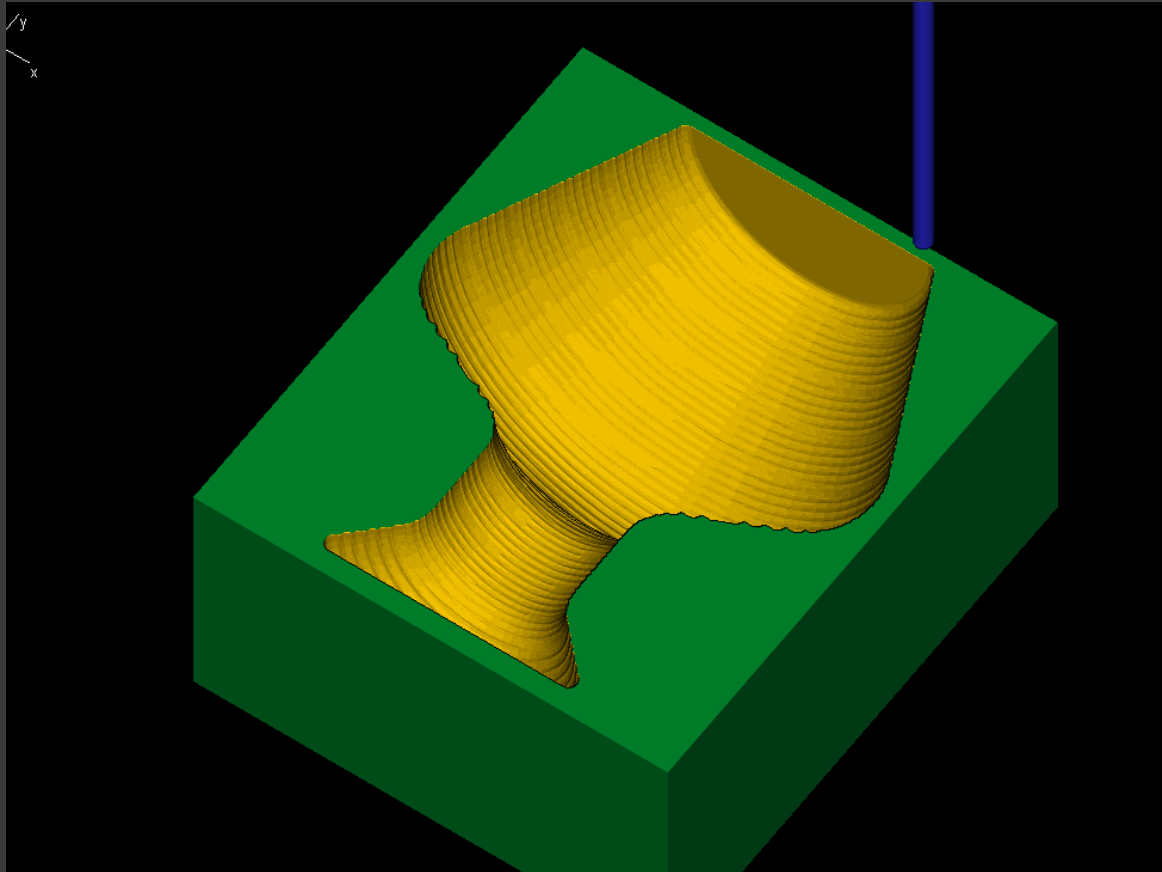

Ruled Surface

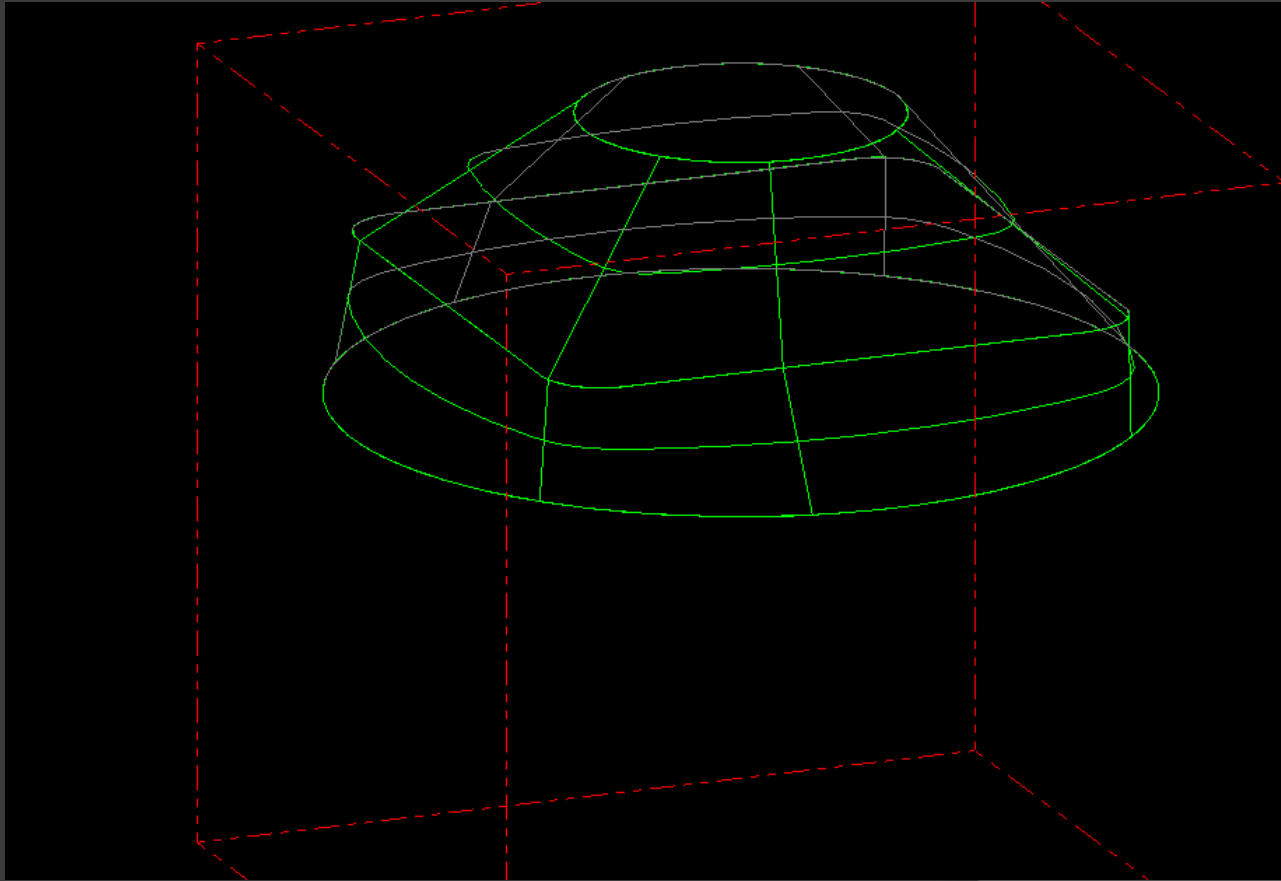

Ruled Surface - Radial

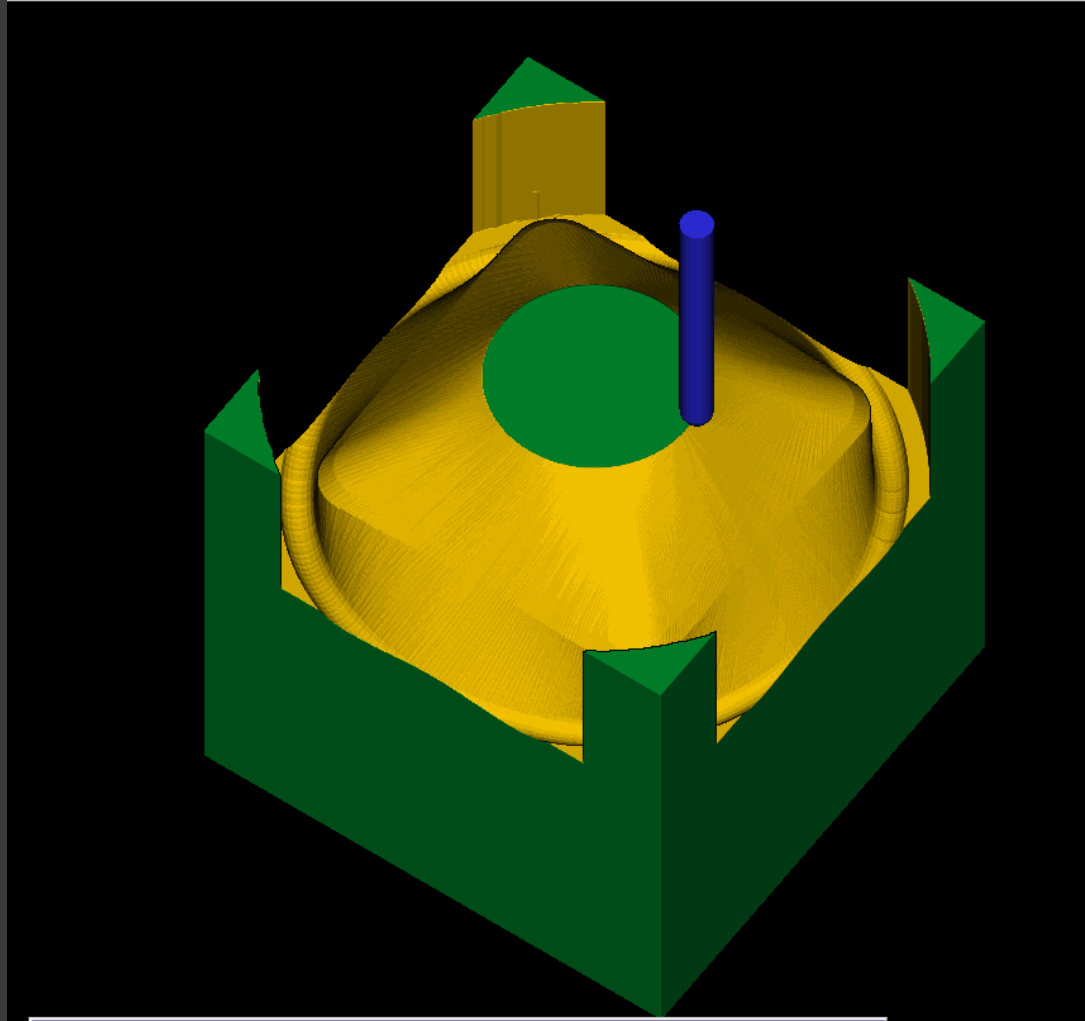

Project 2 – Surface Toolpath

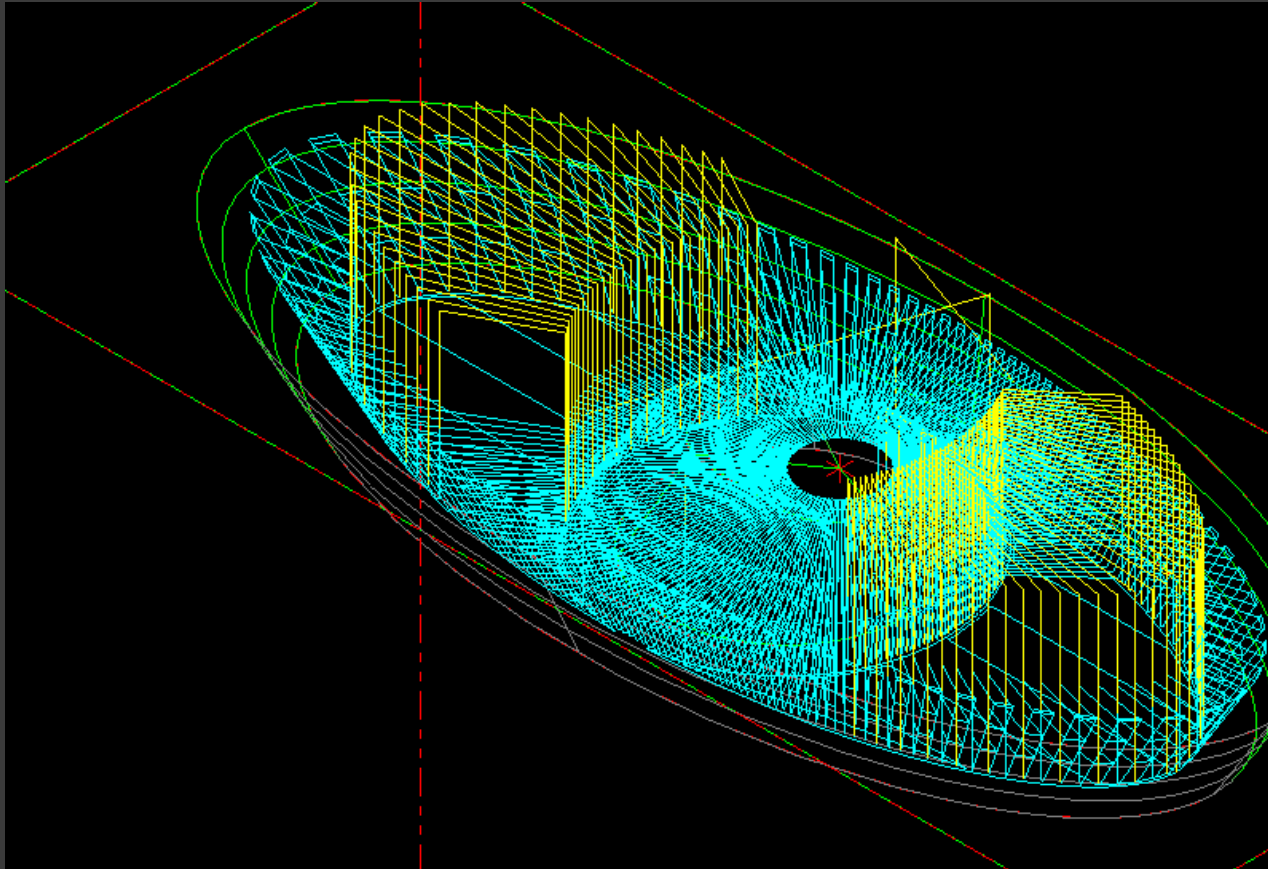

Island Facing and Tapered Walls

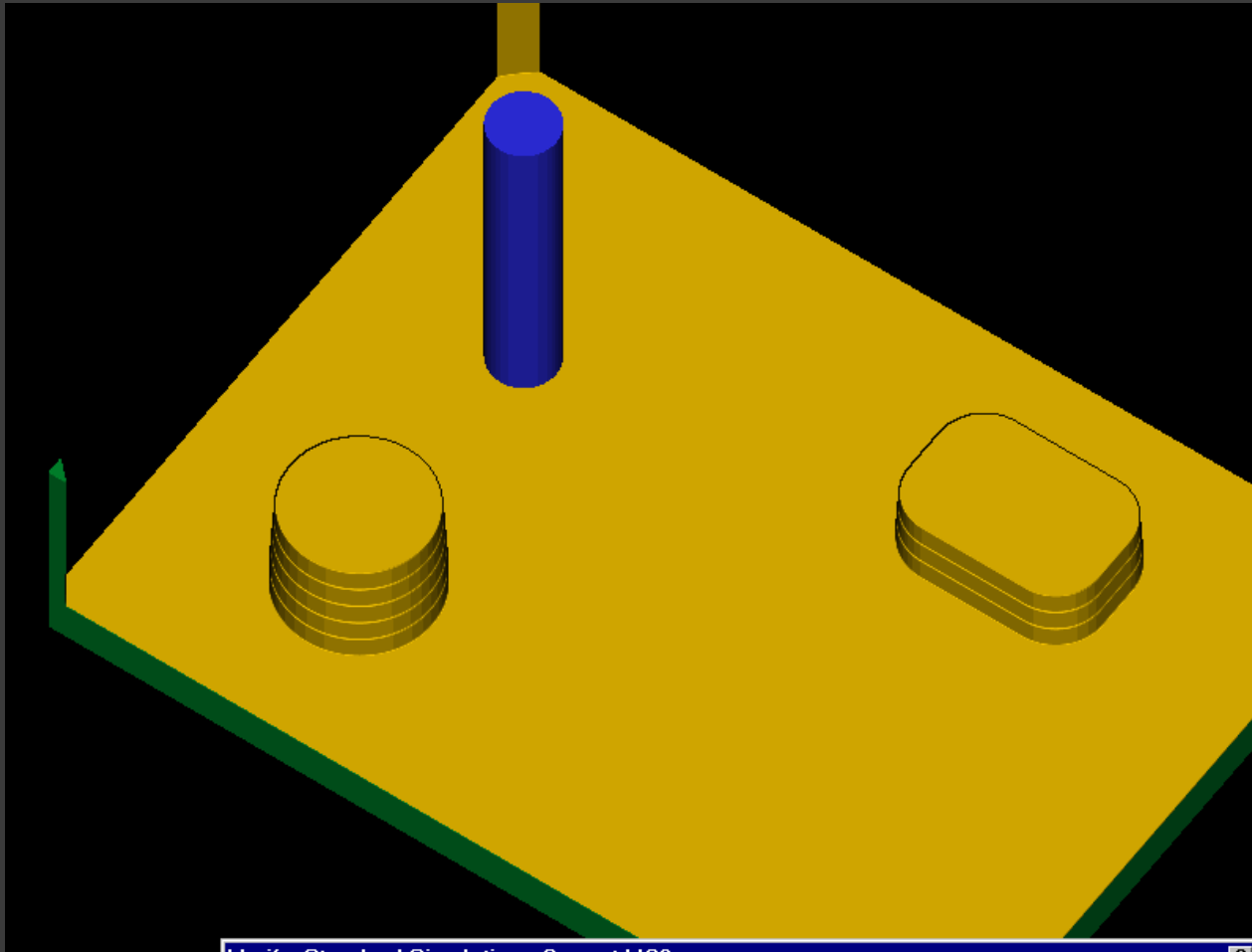

Clip – a Converting ATL file from Solidworks file

